

This article was downloaded by:

On: 25 January 2011

Access details: *Access Details: Free Access*

Publisher *Taylor & Francis*

Informa Ltd Registered in England and Wales Registered Number: 1072954 Registered office: Mortimer House, 37-41 Mortimer Street, London W1T 3JH, UK



Liquid Crystals

Publication details, including instructions for authors and subscription information:

<http://www.informaworld.com/smpp/title~content=t713926090>

Planar and twisted lyotropic chromonic liquid crystal cells as optical compensators for twisted nematic displays

M. Lavrentovich Corresponding author; T. Sergan; J. Kelly

Online publication date: 21 May 2010

To cite this Article Lavrentovich Corresponding author, M. , Sergan, T. and Kelly, J.(2003) 'Planar and twisted lyotropic chromonic liquid crystal cells as optical compensators for twisted nematic displays', *Liquid Crystals*, 30: 7, 851 — 859

To link to this Article: DOI: 10.1080/0267829031000121017

URL: <http://dx.doi.org/10.1080/0267829031000121017>

PLEASE SCROLL DOWN FOR ARTICLE

Full terms and conditions of use: <http://www.informaworld.com/terms-and-conditions-of-access.pdf>

This article may be used for research, teaching and private study purposes. Any substantial or systematic reproduction, re-distribution, re-selling, loan or sub-licensing, systematic supply or distribution in any form to anyone is expressly forbidden.

The publisher does not give any warranty express or implied or make any representation that the contents will be complete or accurate or up to date. The accuracy of any instructions, formulae and drug doses should be independently verified with primary sources. The publisher shall not be liable for any loss, actions, claims, proceedings, demand or costs or damages whatsoever or howsoever caused arising directly or indirectly in connection with or arising out of the use of this material.

Planar and twisted lyotropic chromonic liquid crystal cells as optical compensators for twisted nematic displays

M. LAVRETOVICH*, T. SERGAN and J. KELLY

Liquid Crystal Institute, Kent State University, Kent, OH 44242, USA

(Received 5 January 2003; accepted 11 March 2003)

We have explored the use of lyotropic chromonic liquid crystals (LCLCs) as promising materials for optical compensators for liquid crystal displays. We used aqueous solutions of disodium cromoglycate in the range of concentrations that yield a chromonic N phase. The N phase is aligned by rubbed polyimide layers giving planar orientation. Two different types of LCLC-based elements are described: (a) a uniformly aligned planar N phase that forms an optically uniaxial plate with a negative birefringence; (b) twisted cells of LCLC obtained by doping the N phase with chiral amino acids. Both planar and twisted N* phase cells were used for compensation of the positive birefringence of twisted nematic (TN) displays; the TN devices were appreciably improved. We achieved achromatic dark state and contrast ratio up to 50:1 at all directions within a 40° cone of viewing angle.

1. Introduction

Liquid crystal displays (LCDs) currently dominate the flat panel display market. An ideal LCD would have high contrast and a wide viewing cone free of greyscale inversion. It should also exhibit good colour rendition and an achromatic dark state. The standard uncompensated twisted nematic (TN) device [1] falls short in all of these areas but its defects can to some extent be corrected by optical compensators described in this article.

In LCD applications, the TN cell is viewed between two polarizers that are either parallel ('normally black' or NB mode) or perpendicular ('normally white' or NW mode) to each other. The NB TN cell is in the dark state when no field is applied, as the director undergoes a continuous 90° twist between the two bounding plates. The dark state of the NW mode occurs when the applied field transforms the twisted structure into a homeotropic state (with the director perpendicular to the plates). The leakage of light through the dark state of the device is more serious than the decrease of intensity of the light state. Consequently the compensators are designed for improving the off-state of NB displays and the on-state of NW displays.

The NB TN display mode has a relatively symmetric viewing cone, but suffers from problems with chromaticity and contrast for head-on viewing. The poor viewing angle performance and image inversion of the TN LCD are caused by the positive birefringence of the liquid crystal layer. The dark state of the NB TN cell shows

undesirable light leakage for off-normal view. One can improve the optical performance of the NB TN display by compensating undesirable positive birefringence of the non-activated TN cell with a passive optical retarder. The compensating plate should have negative birefringence and a twisted optical axis that mirrors the director configuration in the TN cell. The twisted structure of a compensation film can be approximated by stacking several layers of polymer film with in-plane negative birefringence [2].

To improve the dark state of a NW TN cell, the compensating film should have a different structure. In the field-on (dark) state a NW TN cell has a complex director configuration with splay deformations near the cell boundaries and vertical orientation in the middle of the cell. A corresponding optical retarder with a negative birefringence and splay optic axis configuration has been developed by Fuji Photo Film [3] and also in this laboratory [4]. The retarder significantly improves the contrast but introduces an undesirable side effect; namely, a yellow colour shift. As a result, one needs additional compensation plates, such as uniaxial films with optic axis in the plane of the film (A-plates) [5]. Negative A-plates can be formed by stretching polymer films; however, this process is poorly reproducible. In previous work [6], we showed that negative birefringence films could be made by the shearing and subsequent drying-down of lyotropic chromonic liquid crystals (LCLCs) based on water solutions of dyes introduced by Optiva Inc. [7]. These are not ideal solutions to the problem however, and a common

*Author for correspondence;
e-mail: marina@lci.kent.edu

drawback of negative A-plates made from stretched polymers and dry LCLC films is their relatively low birefringence.

Negative birefringence films with homeotropic orientation (C-plates) can also improve the optical performance of a NW TN display by optically compensating the mid-layer of the activated TN cell. However, they improve the display performance in one direction only [8, 9]. Thus, in order to achieve high contrast and good colour rendition while employing NW TN mode, one should consider a combination of films.

In the current work we demonstrate that aligned cells of LCLCs (which do not absorb light in the visible part of the spectrum) are promising as compensating optical elements. We describe twisted nematic LCLCs with negative birefringences that compensate NB TN LCDs. We also demonstrate that the optical performance of a NW TN display can be improved by combining the commercially available Fuji film with additional negative A-plates made of uniformly aligned LCLCs that do not suffer from the shortcomings described already for the stretched polymer A-plates or thin oriented dried films.

2. Materials and samples

The basic properties of LCLCs are described in a recent review by Lydon [10]. The LCLC family embraces a range of dyes, drugs, nucleic acids, antibiotics, carcinogens, and anti-cancer agents [10]. The LCLCs are fundamentally different from the better known amphiphilic lyotropic LCs. Qualitatively, the differences are that LCLC molecules are disc-like or plank-like rather than rod-like; their rigid cores are aromatic, and as a rule, they do not have flexible aliphatic parts [10]. Hydrophilic ionic (or hydrogen-bonding) solubilizing groups at the periphery make the LCLC molecules water soluble. Face-to-face stacking of LCLC molecules leads to the formation of columnar aggregates (rather than micelles known for surfactant systems) [10] and thus yields a relatively high negative optical anisotropy. Thin films of dichroic LCLCs can be used both as aligning layers and 'internal polarizers' in TN cells [11, 12].

The LCLC material used in this work is disodium cromoglycate (known as cromolyn) purchased from Aldrich Co. In the concentration range 13–17 wt% the aqueous solution of cylindrical aggregates forms a nematic-like phase [13, 14] referred to as the chromonic N phase [10]. The material is transparent in the visible part of the spectrum. We studied two types of cells: (a) those filled with the N phase, and (b) those filled with the twisted N* phase. The cells of type (a) were especially well suited as compensators of NW TN displays, while combinations of cells (a) and (b) gave compensated NB TN devices. Methods of cell preparation are now described.

(a) Planar cells were fabricated using glass substrates covered with rubbed polyimide (grade 7511 by Nissan Co.) as an alignment layer [15]. The glass plates were separated with fibre spacers made by EM Industries (thickness varied from 4 to 25 μm). The cells were filled with cromolyn–water solutions and sealed with epoxy glue to prevent water evaporation.

(b) Using the amino acids L-alanine and L-lysine [14] as chiral dopants at concentration about 1 wt% we obtained monodomain 90° twisted N* phase cells with an area larger than 4 in^2 . At higher dopant concentrations (above 8 wt%), we observed fingerprint textures typical of the cholesteric phase. Measurement of the period of the fingerprint texture allowed us to estimate the twisting power of the dopants and to optimize their concentration according to the desired twist angle.

The basic active element of the LCDs studied was a TN cell formed by a thermotropic nematic fluid ZLI-4792 (manufactured by Merck) placed between two glass plates with 90° twisted director configuration. The 4–5 μm thick cells were driven in the voltage range 0–6 V.

3. Measurement techniques

In order to determine the optic axis configuration in sealed uniform N cells we employed a null ellipsometry technique based on the de Sénarmont method. The details of the technique can be found in ref. [2]. The result of the measurement is an experimental curve that represents the phase shift in a birefringent sample versus the incidence angle of a testing laser beam. From the shape of this curve it is possible to determine the relative values of the three principal refractive indices, absolute values of birefringence, the optical sign, and the alignment of the optic axis.

To characterize the viewing angle performance of compensated devices, we studied the way in which the contrast ratio varied with the viewing angle by measuring the transmission of the device at various angles when the device was electrically switched between dark and bright states. The ratio between the transmitted luminances in the bright and the dark states was calculated for each angle and the result plotted in the form of iso-contrast curves in polar coordinates (figures 4, 6, 7, 9, later). The circular coordinate of the diagram corresponds to the azimuthal angle, and the radial coordinate corresponds to the polar angle. The centre of the diagram corresponds to head-on viewing, and other points correspond to off-normal directions. The shaded regions correspond to viewing directions for which the contrast ratio is below 100:1.

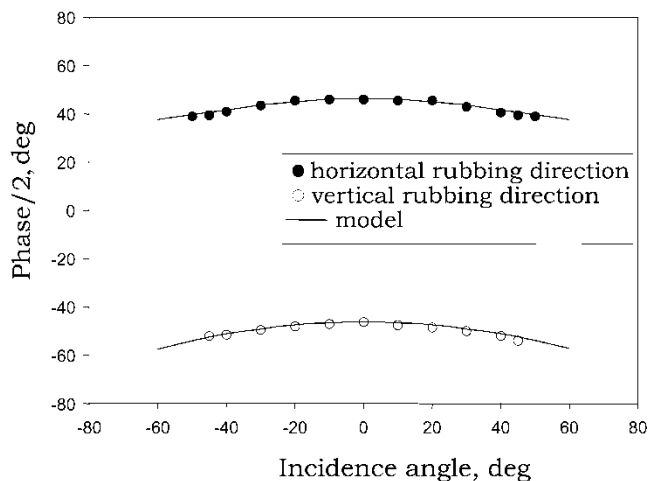

Figure 1. Phase shift versus incidence angle curves for a uniformly aligned cell filled with the N phase of cromolyn.

4. Optical characteristics of planar cells of the cromolyn N phase

We measured the phase shift versus the incidence angle of a testing laser beam for planar cells filled with N phase of cromolyn. Figure 1 shows the characteristic curves that reflect the basic features of an aligned N phase. The structures are uniaxial with the lower refractive index along the director and the higher refractive index in the plane perpendicular to the director. The birefringence of the N phase depends on the concentration and is about $\Delta n = -0.02$ at a cromolyn concentration of 15 wt%. We detected no measurable pretilt angle for planar cromolyn cells.

The N phase cells demonstrated low absorption and low dispersion of visible light. A uniform polarizing microscope texture of the N phase is shown in figure 2(a). The material has optical characteristics similar to those of thermotropic discotic liquid crystals [4]. For this reason, we schematically represent the structure of this phase as a discotic phase.

5. Planar lyotropic cells as negative birefringence compensators of a NW TN device

We propose a new highly effective compensation scheme of the dark state in a NW TN cell. It incorporates the lyotropic planar cells (a) and commercially available retardation films. The scheme yields a very wide viewing angle of NW TN displays and shows tolerance to the thickness of active cell.

The NW TN cell is sandwiched between two sets of compensating elements. Each of these sets contains a lyotropic A-plate (a) with a negative birefringence that can be attached to a standard dichroic polarizer, figure 3(b). To compensate the LCD positive

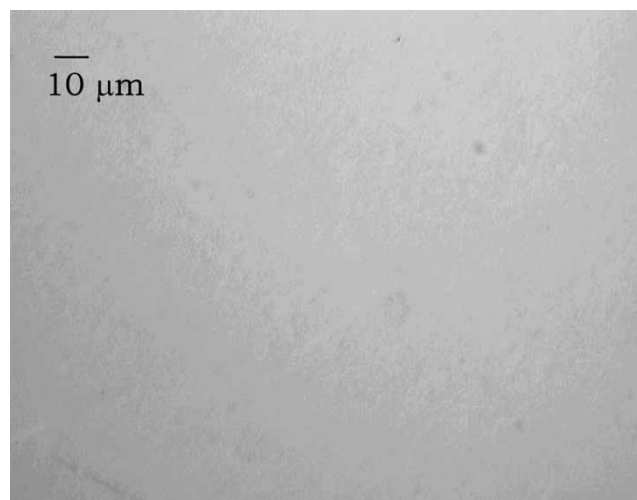

(a)

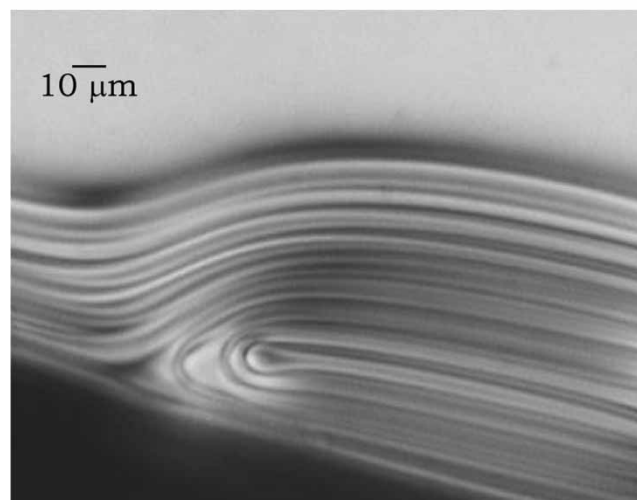

(b)

Figure 2. Polarizing microscope photographs of (a) a planar cromolyn cell containing a homogeneously aligned sample of a 15% aqueous solution, in the chromonic N phase; (b) a cell containing a chirally-doped cromolyn solution, with 8 wt% of L-alanine to give a twisted chromonic N* phase. The texture contains a fingerprint region with the helix axis in the plane of the cell. Note that, in compensating cells containing the N* phase (shown in figure 5), the N* phase is aligned with the helicoidal axis normal to the cell surface.

birefringence of the active layer in the most efficient way, these retardation plates can be coupled with standard Fuji Wide View films [3]. The two negative birefringence cells on the two sides of the TN cell can have different retardation values, however their optical axes should be aligned parallel to the rubbing direction of the adjacent TN plate.

Figure 4(a) shows a computer-simulated performance of the device formed by a 4 μm thick NW TN display, two Fuji Films and two lyotropic (a) cells with

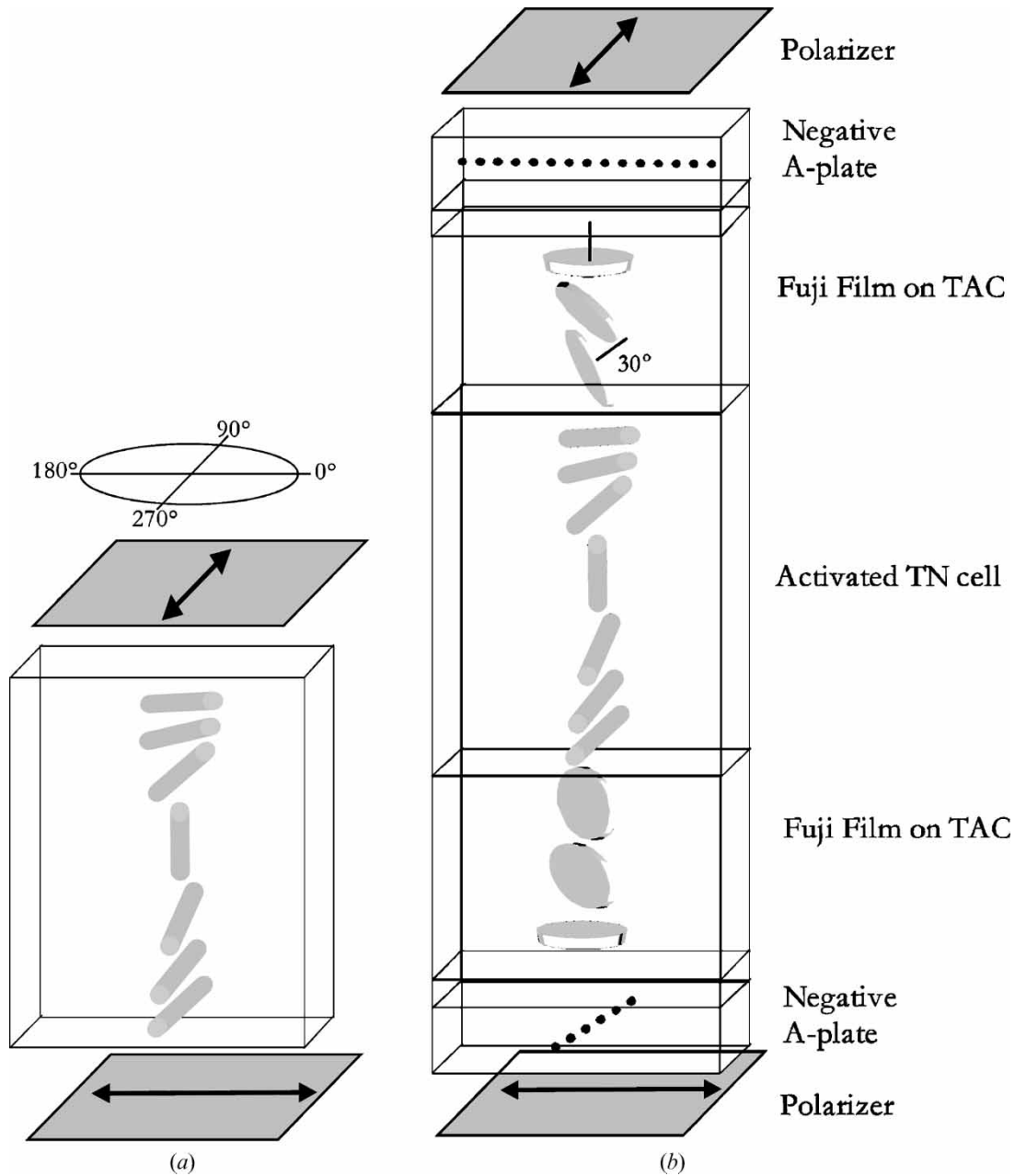

Figure 3. The configuration of a normally white twisted nematic display (shown in the black, on-state): (a) a conventional (uncompensated) NW TN display; (b) a NW TN display compensated with Fuji Wide View films and negative A-plates (planar N phase lyotropic cells).

retardation values of (-82) and (-48) nm (back and front negative A-plates, respectively). Figure 4(a) shows the iso-contrast curves as the function of viewing directions. The model is based on Berreman's 4×4 matrix calculations that provide the exact solution of Maxwell's equations for light propagation in an anisotropic medium [16]. The model predicts a very high

contrast ratio (more than 200:1) over the wide viewing cone.

Figure 4(b) shows the experimental results achieved to date for $4 \mu\text{m}$ thick TN cells compensated by the commercially available Fuji films and our planar lyotropic cells (a) with retardation values about (-80) and (-50) nm, respectively. Optical performance of this

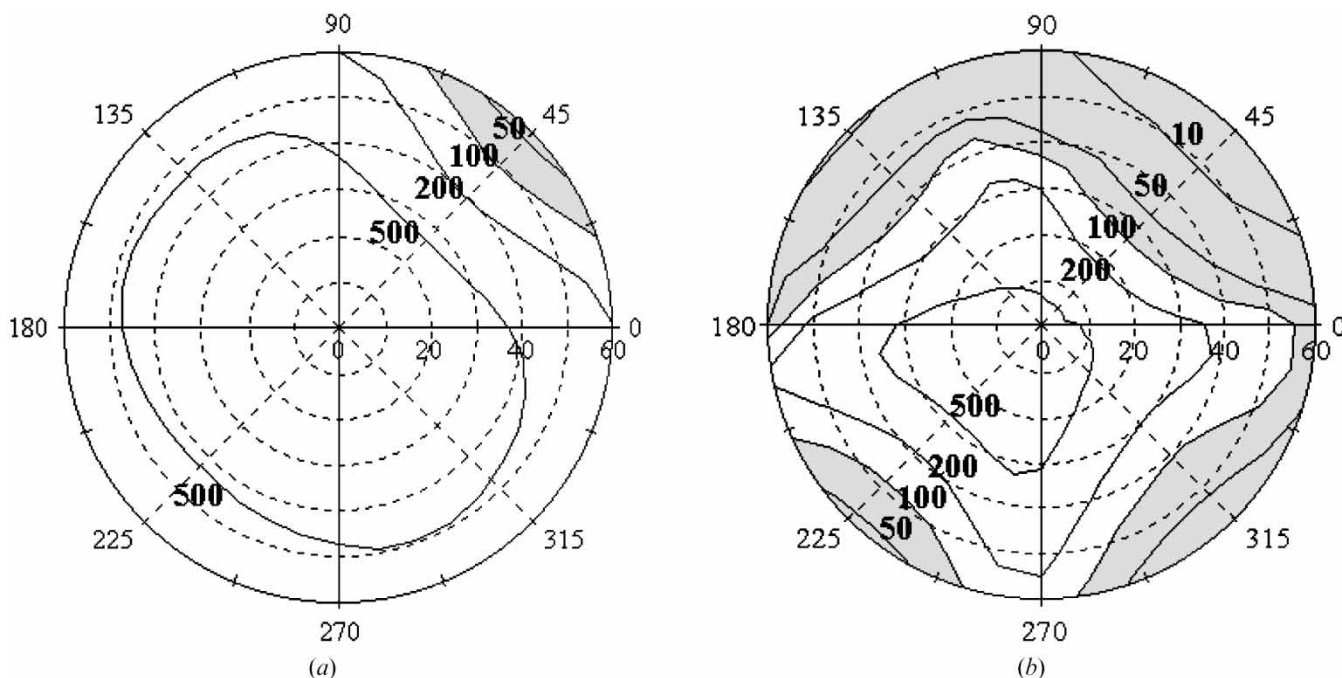

Figure 4. Iso-contrast curves for a NW TN display compensated with Fuji Wide View films and planar N phase lyotropic cells: (a) model, (b) measurement.

display is greatly improved compared with the display with Fuji films alone [3]. Note that the experimental data in figure 4(b) are still not as good as the model data in figure 4(a), because of possible variations in the thickness of the cells and in the alignment direction. The computer model of the chosen compensating configuration shows that its efficiency is sensitive to director misalignment. Another reason might be the temperature sensitivity of birefringence, as the cromolyn N phase has a relatively narrow temperature range [13].

6. Twisted N* phase lyotropic cells as compensators of a NB TN device

The birefringence data for planar lyotropic cells (a) allowed us to build lyotropic TN cells of type (b) with optical birefringence matching that of active TN cells in the NB TN device, figure 5(a). The optical retardation of the thermotropic TN cell of thickness 4–5 μm filled with thermotropic material of birefringence 0.1 is about 0.4–0.5 μm . A similar retardation can be achieved in a lyotropic cell of thickness 20–25 μm , as the optical birefringence of the N phase is about 0.02. To match the director configuration in the thermotropic TN cell, the director in the lyotropic cell should be twisted by 90°. The helicoidal pitch p of lyotropic materials was thus optimized near the value of $p \sim 100 \mu\text{m}$ by studying the fingerprint textures of cromolyn aqueous solutions

doped with different concentrations of chiral amino acids (either pure L-alanine or a mixture of L-alanine and L-lysine) and determining how the pitch depended on the amino acid concentration. Figure 2(b) shows a fingerprint texture of the cromolyn 15% solution in water with an addition of 8 wt% of L-alanine; this composition yields a relatively small pitch $p \sim 10 \mu\text{m}$.

The (right) handedness of twist in lyotropic N* cells was opposite to the left-handed twist in the thermotropic TN cells. The handedness of the doped cromolyn is determined by the relative concentration of amino acids [14]. When the thermotropic and lyotropic cells were placed together between crossed polarizers, the birefringence effects cancelled for all viewing directions, thus providing an achromatic dark state and a wide viewing angle. Figure 5(b) shows the configuration of the resulting NB TN device compensated with the twisted lyotropic cell. Figure 6 shows measured iso-contrast curves for the compensated NB TN device driven by voltages in the range 0–6 V. Comparison with an uncompensated NB TN display [2] shows a substantial improvement in the head-on contrast (350:1 versus 70:1). The shape of the iso-contrast curves (determined primarily by dark state luminance) is similar to iso-luminance curves for dichroic polarizers. The dark state is achromatic at all viewing directions at the polar angles up to 45° [17].

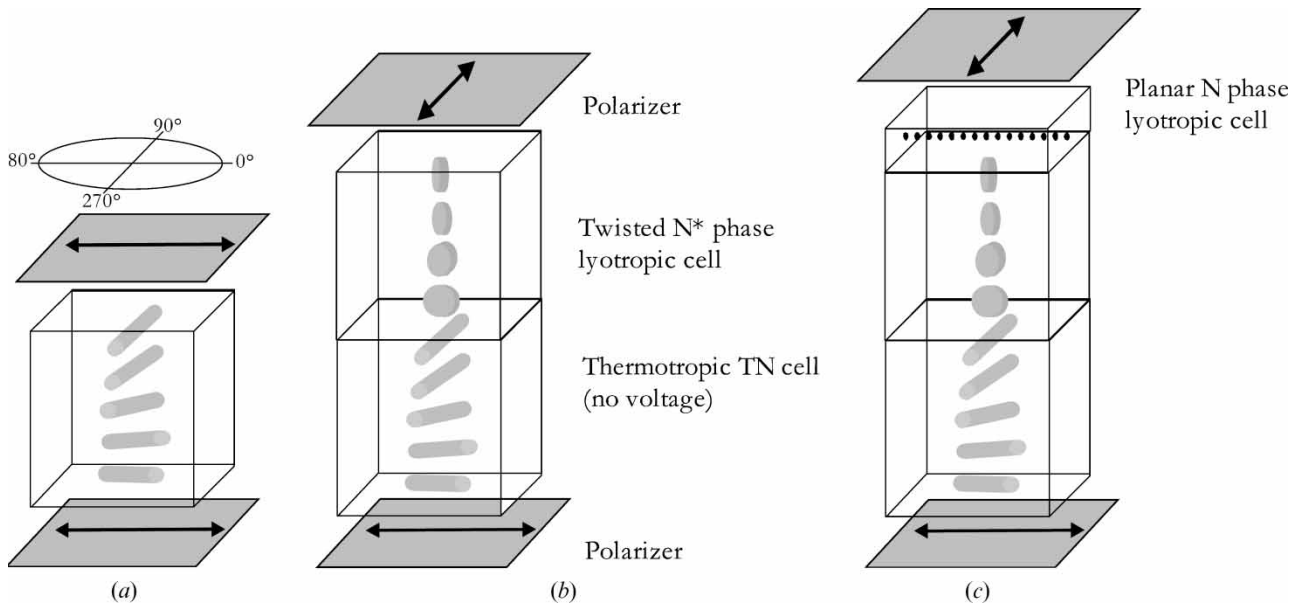

Figure 5. The configuration of a normally black twisted nematic display (shown in the black, off-state): (a) a conventional (uncompensated) NB TN display; (b) a NB TN display compensated with a twisted N* phase lyotropic cell; (c) a NB TN display compensated with a twisted N* phase lyotropic cell and a planar N phase lyotropic cell.

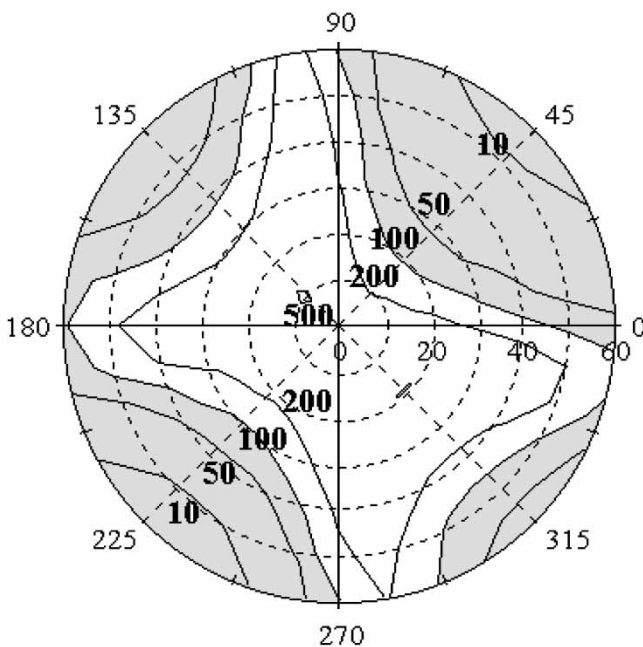

Figure 6. Measured iso-contrast curves for a NB TN display compensated with a twisted N* phase lyotropic cell.

7. Optical performance of NB TN displays compensated with lyotropic cells featuring both twisted and planar optic axis alignment

Light leakage at off-normal directions is detected even for a TN display compensated with an ideal compensation plate, i.e. a plate featuring negative

birefringence and optic axis distribution that mirrors that one for a TN cell. This light leakage is due to an unaccounted birefringence and polarization effects that come from crossed polarizers. The extinction of two crossed polarizers at oblique angles is less than that for the head-on direction even when the polarizers have no birefringence films [18]. Birefringent protective layers used in the commercial production of dichroic polarizers make the problem of off-normal light leakage even worse [19]. The protective films are usually made of birefringent triacetate cellulose (TAC) placed on both sides of the polarizer. The TAC films feature negative birefringence and an optic axis that is perpendicular to the film surface. In order to compensate for the effects caused by polarizers, we developed several compensation schemes that include lyotropic cells with twisted and planar optic axis:

1. A single planar cell of type (a) filled with cromolyn N phase and possessing optical retardation about $(-180)\text{nm}$ compensates the birefringence effects from polarizer protective layers, figure 5(c). Figure 7(a) shows the corresponding simulated iso-contrast curves. The NB TN display compensated with a twisted N* phase cell and a planar cromolyn cell features high contrast (50:1 at polar angles up to 45°) and an achromatic dark state. Figures 7(b) and 8 show iso-contrast and colour performance of the actual TN device compensated according to this scheme.
2. Two lyotropic planar cells (a), that are adjacent

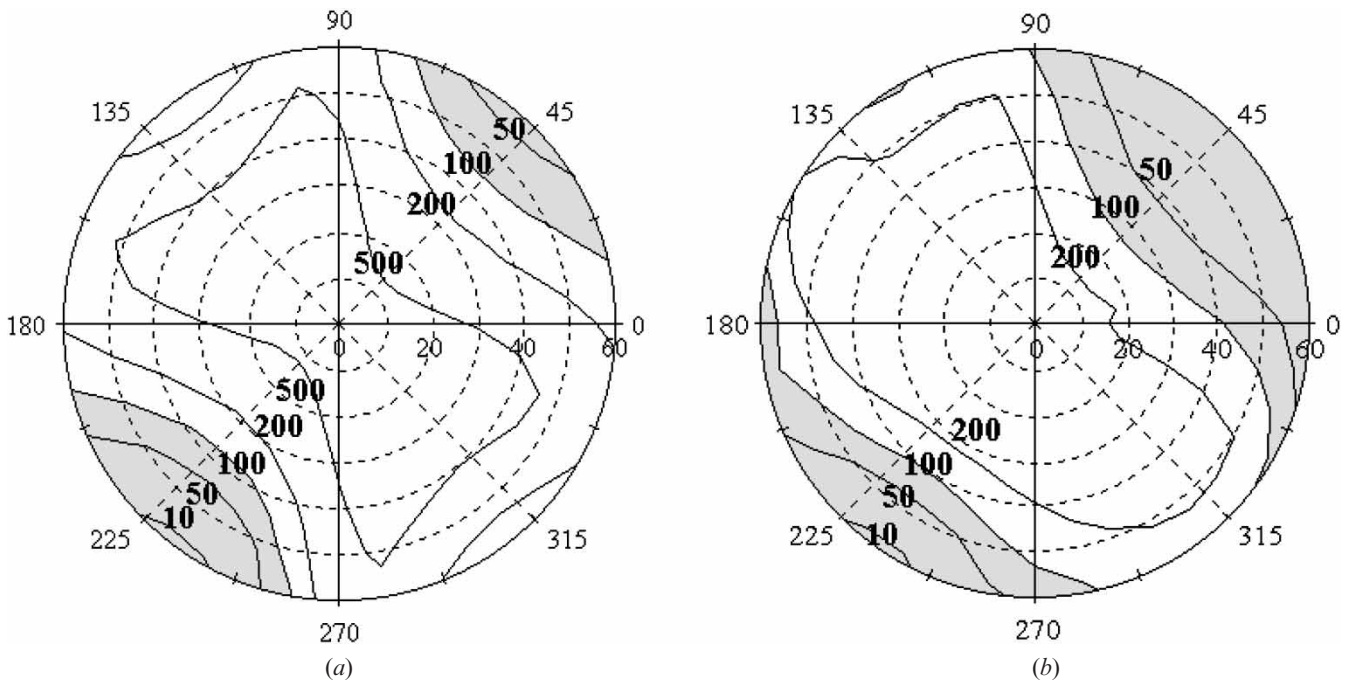

Figure 7. Iso-contrast curves for a NB TN display compensated with a twisted N* phase lyotropic cell and a planar N phase lyotropic cell: (a) model, (b) measurement.

to polarizers, in conjunction with the lyotropic twisted N* cell (b) provide improved chromaticity and high contrast at wide viewing angles.

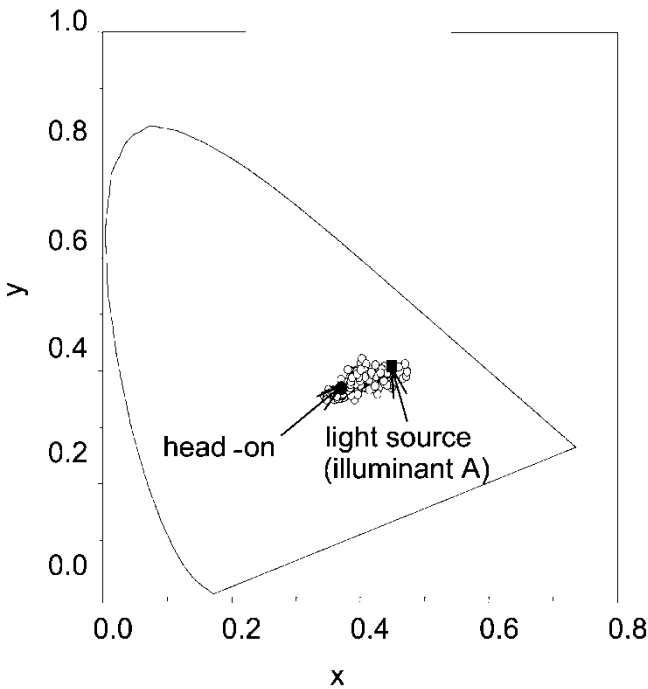

Figure 8. Dark state colour coordinates CIE 1931 at polar angles up to 60° for a NB TN display compensated with a twisted N* phase lyotropic cell and a planar N phase lyotropic cell.

Figure 9 (a) shows modelled iso-contrast curves for a NB TN display compensated with one lyotropic twisted N* cell (b) and two lyotropic planar cells (a) with retardation values (−200) and (−70) nm, respectively. Figure 9(b) shows measured iso-contrast curves for this configuration.

In both schemes, one can notice a quantitative discrepancy between the modelled and measured iso-contrast curves that is most probably caused by a relatively poor control of the optical retardation of the lyotropic plates, as discussed in §5. However, despite these imperfections, the compensated displays possess an achromatic dark state and a very wide and uniform viewing cone. Although no details are presented here, we observed that the grey level performance is very similar in all cases of compensation with lyotropic cells, and is comparable to that described in ref. [2] for a twisted film stack.

8. Conclusions

We have developed different optical schemes to improve the performance of TN displays. As a versatile birefringent material suitable for fabrication of effective optical compensators, we propose LCLCs. The LCLCs can be used in cells with a uniform planar alignment and with a twisted optical axis. The uniaxial planar cells compensate the NW TN displays, while the twisted lyotropic cells and their combinations with the planar

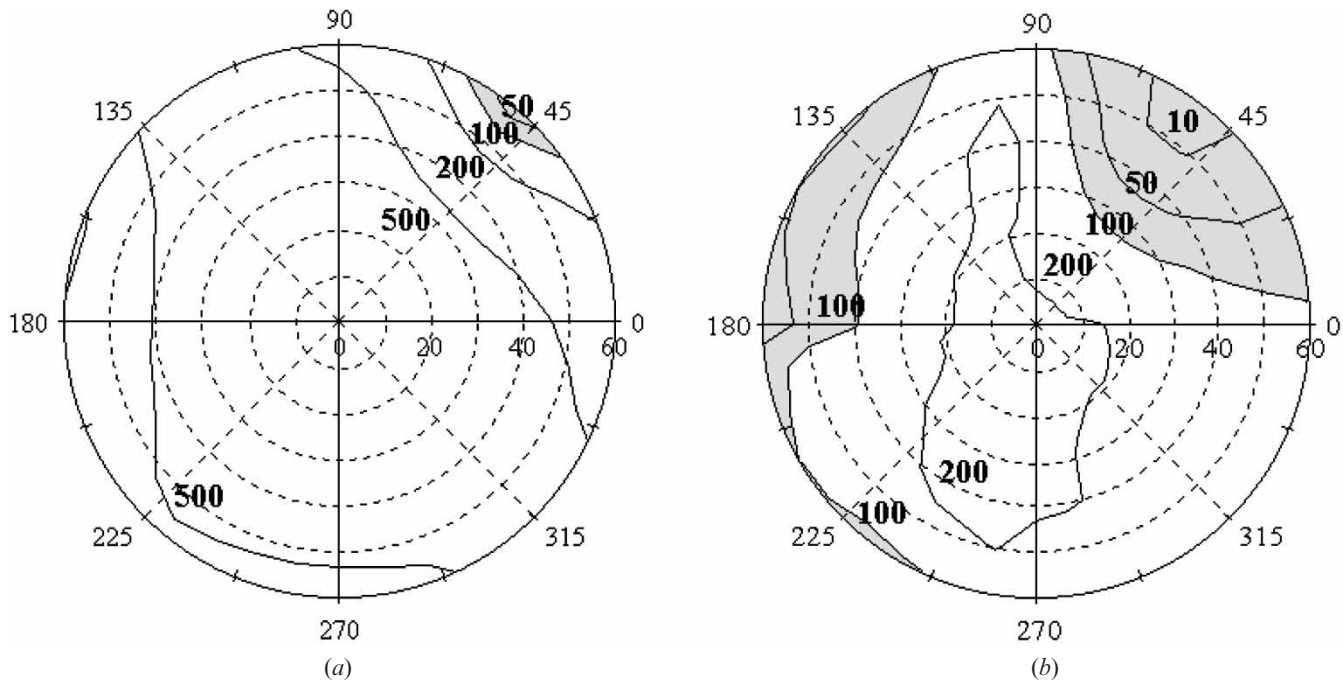

Figure 9. Iso-contrast curves for a NB TN display compensated with a twisted N* phase lyotropic cell and two planar N phase lyotropic cells: (a) model, (b) measurement.

lyotropic cells compensate the NB TN displays. The suggested compensation schemes provide an experimentally verified optical performance that is much better than that of currently manufactured displays. The LCLC compensators provide very wide and uniform viewing cone, high contrast ratios, and an achromatic dark state. Computer modelling demonstrates that there is still room for improvement, as the experimental data do not reach the predicted limits. Further advances can be brought about by the better alignment of LCLCs and stabilization of their properties against temperature and concentration variations. Note that cromolyn and other LCLCs have an important environmental advantage over many materials as their preparation and processing requires only water as solvent. It is important to stress also that the principal schemes of compensation described in this work are universal and can be implemented in commercial production of TN displays not only with cromolyn but also with other birefringent materials.

This research was supported by the National Science Foundation Science and Technology Centre for Advanced Liquid Crystalline Optical Materials (ALCOM) under Contract N. DMR 89-20147.

References

- [1] TSUKADA, T., 1996, *TFT/LCD* (Gordon and Breach Publishers).
- [2] SERGAN, T., LIU, W., KELLY, J., and YOSHIMI, H., 1998, *Jpn. J. appl. Phys.*, **37**, 889.
- [3] MORI, H., ITOH, Y., NISHIURA, Y., NAKAMURA, T., and SINAGAWA, Y., 1996, *AM-LCD'96/IDW'96*, Proceedings of the Third International Display Workshop, Kobe, Vol. 1, pp. 189–191.
- [4] SERGAN, T., SONPATKI, M., CHIEN, L.-C., and KELLY, J., 2001, *Mol. Cryst. liq. Cryst.*, **359**, 245.
- [5] SERGAN, T., and KELLY, J., 1998, *SID'98 Dig.*, pp. 694–697.
- [6] SERGAN, T., and KELLY, J., 2000, *Liq. Cryst.*, **27**, 1481.
- [7] KHAN, I. G., BOBROV, YU. A., BYKOV, V. A., IGNATOV, L. Y., and LAZAREV, P. I., PCT/US97/05423, publication number WO 97/39380.
- [8] SERGAN, T., JAMAL, S., and KELLY, J., 1999, *DISPLAYS*, **20**, 259.
- [9] ONG, H. L., 1992, *Japan Display '92 Digest*, p. 247.
- [10] LYDON, J., 1998, *Curr. Opin. colloid interface Sci.*, **3**, 458.
- [11] SERGAN, T., SCHNEIDER, T., KELLY, J., and LAVRENTOVICH, O. D., 2000, *Liq. Cryst.*, **27**, 567.
- [12] SCHNEIDER, T., and LAVRENTOVICH, O. D., 2000, *Langmuir*, **16**, 5227.
- [13] LEE, H., and LABES, M. M., 1983, *Mol. Cryst. liq. Cryst.*, **91**, 53.
- [14] LEE, H., and LABES, M. M., 1982, *Mol. Cryst. liq. Cryst.*, **84**, 137.
- [15] LAVRENTOVICH, O. D., and ISHIKAWA, T., 2002, U.S. Patent 06411354.
- [16] BERREMAN, D. W., 1972, *J. opt. Soc. Am.*, **62**, 502.

- [17] LAVRETOVICH, M., SERGAN, T., and KELLY, J., in Proceedings of the 19th International Liquid Crystal Conference, Edinburgh, 2002, to be published in *Mol. Cryst. liq. Cryst.*
- [18] CHEN, J., KIM, K.-H., JYU, J.-J., SOUK, J. H., KELLY, J. R., and BOS, P. J., 1998, *SID'98 Dig.*, pp. 315–318.
- [19] HERKE, R., JAMAL, S., and KELLY, J., 1995, *J. SID*, **3/1**, 9.